

500-EXCELLENT SERIES BS-MODELS



Effective and immediate removal of food waste is a necessity in a kitchen or galley. It is therefore important that Disperator food waste disposers be installed in sinks and washing lines where food waste is produced. This is possible with our wide range of mounting assemblies.

The nipple attachment of Disperator 500 Excellent Series BS-Model is welded into the 80 mm drain hole in the bottom of the sink unit. A plate bolted to the disposer is threaded to nipple.

The disposer is delivered complete with start & stop controler and motor protector, solenoid valve and line strainer.

The assembly come complete with flushing nozzle and a removable combined cutlery trap and feeder. A flush pipe, with air gap to sink, is available as optional.

The 500 Excellent Series BASIC models must be assembled with an ATF-, ATV-, BS-, HK-, MI- or DRR-K-assembly before CE-certification is given.

The Disperator 500 Excellent Series has Det Norske Veritas (DNV) Approval for compliance with IMO MARPOL 73/78 ANNEX V for disposal of ground food waste into the open sea.

Further details are specified overleaf.

Disperator AB

Mälarvägen 9, SE-141 71 Segeltorp, Sweden
Tel +46 8 724 01 60, Fax +46 8 724 60 70
info@disperator.se, www.disperator.se



MADE IN SWEDEN

Ref: BS/Prod/Eng/091014

500-EXCELLENT SERIES BS-MODELS

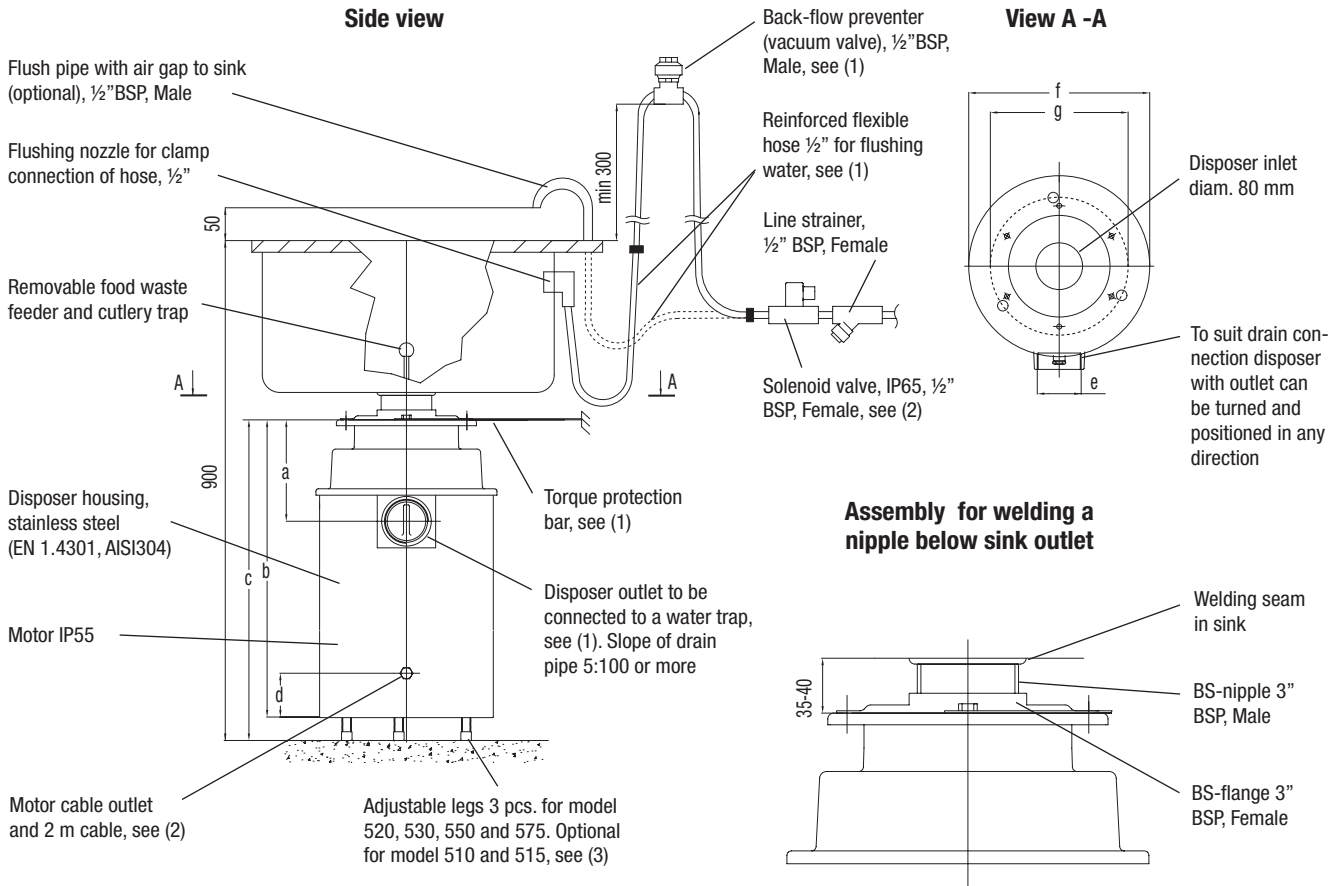

All measurements in mm

Technical Specification	510-BS	515-BS	520-BS	530-BS	550-BS	575-BS
Normal capacity, kg/hr	300	400	500	700	850	1000
Electrical power, kW	0,75	1,1	1,5	2,2	4,0	5,5
Rated current, A for:						
230 V / 3 ph. / 50 Hz	3,7	4,6	5,9	9,0	14,4	19,7
400 V / 3 ph. / 50 Hz	2,1	2,6	3,4	5,2	9,0	11,5
440 V / 3 ph. / 60 Hz	2,1	2,4	3,5	5,2	7,5	11,6
Other 3-ph voltages available	1-ph 220-240V, 50/60Hz also available for models 510 and 515					
Control voltage	For marine installation the same as motor voltage. For land installation 230V / 50HZ					
Fuse rating, slow	10 A	10 A	10 A	16 A	16 A	25 A
Gross / net weight, kg	30 / 27	33 / 30	38 / 35	46 / 43	49 / 46	58 / 55
Measurement a	151	151	151	176	176	176
Measurement b	425	425	568	545 see (4)	545 see (4)	640
Measurement c	See (3)	See (3)	591-715	570-635 see (4)	570-635 see (4)	665-730
Measurement d	40	40	40	75	75	75
Measurement e	2 "	BSP,	Female	2 1/2 "	BSP,	Female
Measurement f	253	253	253	310	310	310
Measurement g (legs)	See (3)	See (3)	204	236	236	236

- (1) Installation material needed but not incl. in standard delivery are electrical connection terminal / main switch, flexible hose 1/2", backflow preventer, water trap and torque protector. Can be ordered from DISPERATOR.
- (2) For connection to start & stop controller (IP55, incl. overload protector) placed on wall / bulkhead. Controller to be connected to terminal / main switch, see (1).
- (3) 3-ph standard without legs. Legs available as option – and then with same measurements b), c) and g) as model 520. Models 510, 515 1-ph have same measurements b), c) and g) as model 520.
- (4) Short version (b = 510 mm and c = 522–593 mm) and longer version (b = 640 mm and c = 665–730 mm) available as option.
- (5) Installation, operation and service instructions are together with this product leaflet included in delivery.

Disperator AB

Mälärvägen 9, SE-141 71 Segeltorp, Sweden
 Tel +46 8 724 01 60, Fax +46 8 724 60 70
 info@disperator.se, www.disperator.se